

Gasoline  
7 kW 60 Hz



## Commercial GenSet

- First EFI (Electronic Fuel Injection) GenSet in its Class
- EFI Provides Improved Hot and Cold Start Capability
- Integrated Hydraulic Pump Option (Pictured)
- Quietest and Lowest Vibration GenSet in Its Class
- Integrated Housing Design
- Enclosed Muffler for Ease of Installation
- Self-Diagnostic Capability to Simplify Troubleshooting
- Runs Two ACs With Power to Spare
- Digital Regulation for Voltage Stability as Loads Change
- Electronic Governor for Voltage Stability and Frequency Control
- 2-Year Limited Warranty, 5-Year Drive Warranty

## Models and Ratings

<u>Model</u>	<u>Fuel</u>	<u>Hz</u>	<u>Watts</u>	<u>Voltage</u>	<u>Amps</u>	<u>PF</u>	<u>Phase</u>	<u>Circuit Breaker</u>
7 HGJAD-2139+	Gasoline	60	7000	120	58.3	1.0	1	2 pole, 30 Amp
7 HGJAD-2559+#	Gasoline	60	7000	120/240	29.2	1.0	1	2 pole, 30 Amp
7 HGJAD-2560+#	Gasoline	60	7000	120/240	29.2	1.0	1	2 pole, 30 Amp
7 HGJAD-2141+	Gasoline	60	7000	120/240	29.2	1.0	1	2 pole, 30 Amp
7 HGJAD-1910*+#	Gasoline	60	7000	120/240	29.2	1.0	1	2 pole, 30 Amp

- All 60 Hz models operate at 2880 r/min.

- Ratings apply up to 3000 ft (914 m) altitude, 85° F (29.4° C).

- Derating: Power output will decrease 3.5% for each 1000 ft (305 m) above 3000 ft (914 m), temperature derate not required for ambient\*\* temperatures under 120° F (49.2° C).

- Ratings are at intermittent power output. Continuous ratings are 90% of intermittent.

\*Hydraulic pump standard

+EFI Gensets require a chassis-specific fuel system kit. See F-1106, Onan Commercial Mobile Accessories and Service Support Catalog.

#Splined shaft

\*\*Ambient is defined as the air temperature measured at the cooling air inlet to the set.

## Weight, Size and Sound Level

- 290 lb (132 kg)
- Length 33.6 in (853 mm), Width 22.2 in (563 mm), Height 16.7 in (425 mm)
- 60 Hz, 69 dB(A) at 10 ft (3 m), typical installation, full load

## Standard Features

- Electronic Fuel Injection (EFI) for clean, smooth running under all conditions
- Electronic governor
- Onan Performer™ OHV engine
- Pressurized Thru Flow cooling system
- 4-point mounting system with coil spring vibration isolators
- Universal mounting tray with structural capability to support the genset in commercial mobile applications
- Integral USDA Forest Service-approved spark-arrestor muffler
- Integral control box
- Instant one-touch stop switch
- Electronic ignition
- Self diagnostic capability
- Hour meter
- Battery charging - 5 amps
- Remote disable/continuous stop
- Start and run without AC output - engine run only
- Enclosed muffler provides noise reduction and ease of installation
- Sound-attenuated housing
- Waterproof remote connector
- Heavy-duty solenoid shift starter
- Long-life fuel filter
- Spin-on, full-flow oil filter
- Low oil pressure protection
- Overspeed/underspeed protection
- Low power factor field overcurrent protection
- Digital voltage regulation
- Hydraulic pump standard on some models
- 10 ft generator output leads

## Accessories

- Remote control start/stop rocker switch (part #300-5331)
- Remote control with start/stop switch and hour meter (part #300-5332)
- Remote control with start/stop switch and DC voltmeter (part #300-5333)
- Remote control plug and wire harness 10 ft (part #338-3489-01), 30 ft (part #338-3489-02)
- Remote harness (300-4946) pigtail harness to connect to sealed remote connector
- Battery, 12 V, 380 cold cranking amps at 0° F (-18° C) (part #416-0579) (dry)
- Underfloor mounting kit (part #405-6699)
- Installation template (part #539-2057)
- Tailpipe kit 22 in (part #155-3481-01), 26 in (part #155-3481-02) Exhaust tube, straight with flanged end 3 in (part #155-2610), 7 in (part #155-2424), 12.5 in (part #155-2610-01)
- Exhaust elbow, tight radius 90° to route exhaust through cutouts (part #155-3439)
- EFI Gensets require a chassis-specific fuel system kit. See F-1106, Onan Commercial Mobile Accessories and Service Support Catalog.

## Basic Dimensions

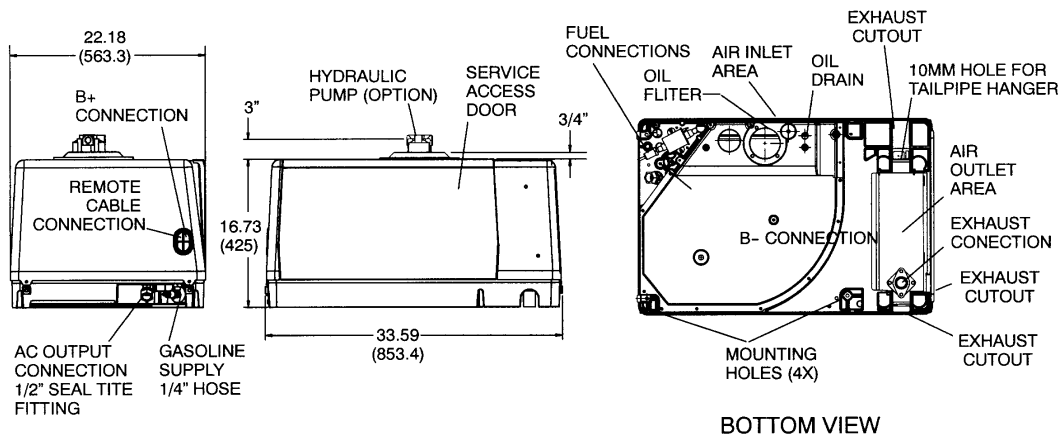

This outline drawing is provided for general reference only and is not intended for design or installation. For more information see installation manual or obtain outline drawing 500-3449 and wiring diagram from your Distributor/Dealer.

---

## Engine Detail

**Model:** Onan Performer™ OHV EH65V gasoline engine

**Design:** 4-cycle, OHV, 90-degree V-Twin

**Cylinders:** 2

**Bore:** 80 mm

**Stroke:** 65 mm

**Displacement:** 39.8 in<sup>3</sup> (653 cm<sup>3</sup>)

**Compression ratio:** 8:1

**Oil capacity:** 2.0 qt (1.9 L) including filter

**Power (max):** at 2880 r/min: 14.0 hp

**Cooling:** Centrifugal blower, generator mounted for high effectiveness, pressurized system, vertical flow

Cooling air volume: 60 Hz: 500 ft<sup>3</sup>/min (14.2 m<sup>3</sup>/min) at 2880 r/min. Air flow includes engine, generator, and control cooling air flow

**Fuel System:**

- Replaceable dry element air cleaner

- Gasoline - sidedraft throttle body

Remote mount electronic fuel pump with positive fuel shutoff (45 psi), maximum fuel lift 3 ft (0.9 m)

- Combustion air volume: 60 Hz: 18.9 ft<sup>3</sup>/min (0.53 m<sup>3</sup>/min) at 2880 r/min

**Typical fuel consumption**

Gasoline, Gal/hr (L/hr)

	No load	Half load	Full load
7.0 HGJAD	0.42 (1.6)	0.73 (2.8)	1.22 (4.6)

**Starting system:** Remote, 12 V, negative ground; automotive type starter with steel pinion and ring gear, automatic start disconnect, connector for remote start cable, start-stop rocker switch mounted on set control

**Ignition system:** Electronic magneto type with resistor plugs

**Lubrication:** Full pressure positive displacement lube oil pump, spin-on, full-flow lube oil filter, low oil pressure shutdown, dipstick

**Cylinder-crankcase:** Alloy aluminum with iron cylinder liners cast into the block, aluminum oil base

**Cylinder head:** Aluminum, overhead valve, removable

---

## Alternator Detail

**Design:** Onan, revolving field, AC, 2-pole self-excited, two bearing design

**Insulation system and temperature rise:** Meets requirements of NEMA MG-1 and CSA C22.2, No. 100, motors and generators

**Cooling:** Direct drive centrifugal blower, cast aluminum housing for excellent heat transfer

**Rotor:** Laminated electrical steel assembly press-fitted to shaft, balanced; heavy insulated copper wire windings; optimized air gap for improved waveform and motor starting; class 200 magnet wire

**Stator:** Laminated electrical steel assembly, skewed for improved waveform; class 200 quadrature wire with 70% more insulation over comparable gensets

**Excitation:** Capped, digital voltage regulation

**DC Brushes:** Electrographic; long life  
**Bearing:** Double-sealed prelubricated ball bearings

---

## GenSet Detail

	No load - full load	Constant load
Frequency regulation	1.7%	1.7%
Voltage regulation	2.0%	1.7%

**Hydraulic pump**

Fixed displacement gear pump, 1.8 Gal/min at 2500 psi

A genset with a hydraulic pump is rated with the pump idle.

When using a non-Onan pump supplied by the customer, the hydraulic pump shaft seals must be capable of operating in a temperature environment of 225° F to 250° F. Seal failure will result in equipment damage.

---

## Warranty Policy

The ONAN limited warranty covers virtually everything except routine maintenance for the first two years that you own your generator set, or the first 2,000 hours of operation, whichever comes first; five years on drive system. In addition, it includes a free 90-day adjustment policy, which provides that Onan will make minor adjustments to your new genset during the first three months you own it - free of charge!

For complete Onan limited warranty details see your certified Onan Distributor/Dealer.

---

## After Sale Support

**EASY TO LOCATE CERTIFIED ONAN SERVICE AND PARTS DEALERS** - Onan has the largest and best-trained worldwide certified Distributor/Dealer network in the industry, offering on-time parts and service, and installation assistance. Cummins Onan Distributor/Dealers stock and sell commonly used Onan GenSet maintenance parts, accessories and products, plus operator manuals and literature on current Onan GenSets. They can help you select and install the right genset or accessories on older models, or provide answers to questions on proper operation and maintenance procedures.

**MANUALS** - Installation and operators manuals are shipped with the genset. To obtain additional copies or other manuals for this model, see your Cummins Onan Distributor/Dealer and request the following part numbers: Operators Manual (983-0102), Parts Manual (983-0202), Service Manual (983-0501), and Installation Manual (983-0601).

---

## Standards and Testing

Tested at extremes of temperature -20° F to 120° F for starting and operation. Tested installed.

Tested with commercial loads.

Tested in high humidity conditions.

Tested in salt spray conditions.

Tested in heavy air borne dust conditions.

Field Test Program.

This generator set meets exhaust emissions regulations for U.S. EPA Phase 2 and California MY 2002-MY-2005 for small off-road engines.

This generator set was designed and manufactured in facilities certified to ISO 9001.

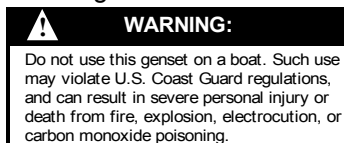

---

**Contact your Distributor/Dealer for more information:**



To easily locate the nearest Onan Distributor/Dealer, or for more information, contact Onan at 1-800-888-ONAN or 763-574-5000; 1400 73rd Avenue N.E., Minneapolis, MN 55432 U.S.A.; fax 763-574-5298; e-mail [pgamail@cummins.com](mailto:pgamail@cummins.com); [www.onan.com](http://www.onan.com).

Cummins Power Generation is a subsidiary of Cummins Inc. Onan is a registered trademark of Cummins Inc.

**WARNING:** Backfeed to utility systems can cause electrocution or property damage. Do not connect to building electrical except through approved device and after building main breaker is opened.