



## RV GenSet

- Perfect for Travel Trailers, Truck Campers, and Folding Camping Trailers
- Runs One Air Conditioner with Power to Spare
- Lightweight, Compact, and Easy to Install
- Easy Maintenance with Single-Side Service
- Low Fuel Consumption
- Gasoline or LP Fueled
- 3-Year Limited Warranty

## Ratings and Models

Model	Fuel	Hz	RPM	Watts	Voltage	Amps	Phase	Circuit Breaker
2.8 KVD-2090	Gasoline	60	3600	2800	120	23.3	1	25A
2.5 KVD-2089	LP Vapor	60	3600	2500	120	20.8	1	25A
2.3 KVD-3729	Gasoline	50	3000	2300	230	10.0	1	10A
2 KVD-3730	LP Vapor	50	3000	2000	230	8.7	1	10A

- Ratings apply to altitudes up to 500 ft (152.4 m), 85°F (29.4°C).

- Derating: Power output will decrease 3.5% for each 1,000 ft (305 m) above sea level and 1% for each 10°F (5.5°C) increase in ambient temperature above 85°F (29°C).

## Weight, Size and Sound Level

- **Weight:** 107 lbs (48 kg)
- **Size:** Length 19.6 in (498 mm), Width 16.7 in (424 mm), Height 12.3 in (312 mm)
- **Sound:** 60 Hz-71 dB(A) at 10 ft (3 m), half load in typical RV installation; 50 Hz-64 dB(A) at 10 ft (3 m), half load in typical RV installation

## Standard Features

- Onan sound-attenuating enclosure
- Focalized mounting system with vibration isolators
- Cross-flo cooling
- Sheet steel drip controlling base
- USDA Forest Service approved spark arrestor muffler kits available
- Adjustable mechanical governor
- Automatic choke
- Overhead valves
- Single-side service
- Electric fuel pump (gasoline); electric fuel solenoid (LP)
- Mounted control panel
- Sealed remote start connector
- Electric start
- Fused DC circuits to protect set wiring and remote control wiring
- Magnetic circuit breaker
- 120 in (3 m) generator output leads
- Solid-state ignition

## Engine Detail

**Model:** Onan GH-200  
**Design:** 4-cycle, single cylinder, overhead valve  
**Displacement:** 12 in<sup>3</sup> (197 cm<sup>3</sup>)  
**Compression Ratio:** 8.5:1  
**Power:** 7.0 bhp (max) at 3600 r/min  
**Cooling:** Pressurized air  
**Fuel System:** (Gasoline) electric fuel pump, fuel lift 3 ft (914 mm); (LP) Electric fuel solenoid; automatic choke  
**Combustion Air:** 60 Hz: 12.5 ft<sup>3</sup>/m (0.35 m<sup>3</sup>/min) at 3600 r/min; 50 Hz: 10.4 ft<sup>3</sup>/m (0.3 m<sup>3</sup>/min) at 3000 r/min  
**Average Fuel Consumption:**

Gasoline	No Load		Half Load		Full Load	
	gph	l/h	gph	l/h	gph	l/h
60 Hz 2.8 KVD	0.2	0.8	0.3	1.1	0.4	1.6
50 Hz 2.3 KVD	0.2	0.8	0.2	0.9	0.4	1.5

LP Vapor	No Load			Half Load			Full Load		
	gal/h	lb/h	kg/h	gal/h	lb/h	kg/h	gal/h	lb/h	kg/h
60 Hz 2.5 KVD	0.2	0.9	0.4	0.4	1.5	0.7	0.6	2.4	1.1
50 Hz 2.0 KVD	0.2	0.9	0.4	0.3	1.3	0.6	0.5	2.2	1.0

**Ignition System:** Breakerless, electronic  
**Starting System:** Remote, 12 V, 3-wire negative ground, start-stop rocker switch on control  
 Connector for remote start cable  
**Lubrication:** Splash lubrication  
**Oil Capacity:** 1 qt (0.95 L)  
**Cylinder-Crankcase:** Alloy aluminum with iron cylinder liner cast into the block  
 Aluminum oil base  
**Cylinder Head:** Alloy aluminum, removable

## Generator Detail

**Design:** Onan 2-pole self-excited revolving field  
 Permanently aligned to engine by a tapered shaft  
 Drip-proof construction  
**Insulation System and Temperature Rise:** Meets ANSI/RVIA EGS-1, BS-4999 standards, and CSA 946 standards  
**Cooling:** Direct Drive Centrifugal Blower. Air required: Includes engine cooling air 300 ft<sup>3</sup>/m (8.5 m<sup>3</sup>/min) at 3600 r/min

**Rotor:** Laminated electrical steel assembly press-fitted to shaft, balanced, heavy insulated copper wire windings  
**Stator:** Laminated electrical steel assembly skewed for excellent waveform. Heavy insulated copper wire windings.  
**Voltage Regulator:** Electronic  
**DC Brushes:** Electrographitic

## GenSet Performance

**Air Conditioner Operation:**  
**60 Hz:** at 500 ft. (152.4 m and 100°F (38°C)). The 2.8 KVD genset will start and run one approved 13500 BTU air conditioner (14.7 cooling amps or less) plus a 600-watt baseload, or one approved 11000 BTU air conditioner plus a 1000-watt baseload. The 2.5 KVD will start and run one approved 13500 BTU air conditioner plus a 300-watt baseload, or one approved 11000 BTU air conditioner plus a 600-watt baseload.  
**50 Hz:** at 500 ft. (152.4 m and 100°F (38°C)). The 2.3 KVD will start and run one 7800 BTU air conditioner (5.5 cooling amps or less) with a 600 W baseload. The 2.0 KVD will start and run one 7800 BTU air conditioner (5.5 cooling amps or less) with a 300 W baseload.  
 Note: Air conditioners operating on engine driven generators require "easy start" circuits.

**Voltage Regulation:** Exceeds requirements of ANSI/EGS-1 ±10%  
**Frequency Regulation:** Exceeds requirements of ANSI/RVIA EGA-1 ± 5%

# Basic Dimensions

## Muffler Kit 541-0618 - Not for use on 50 Hz models

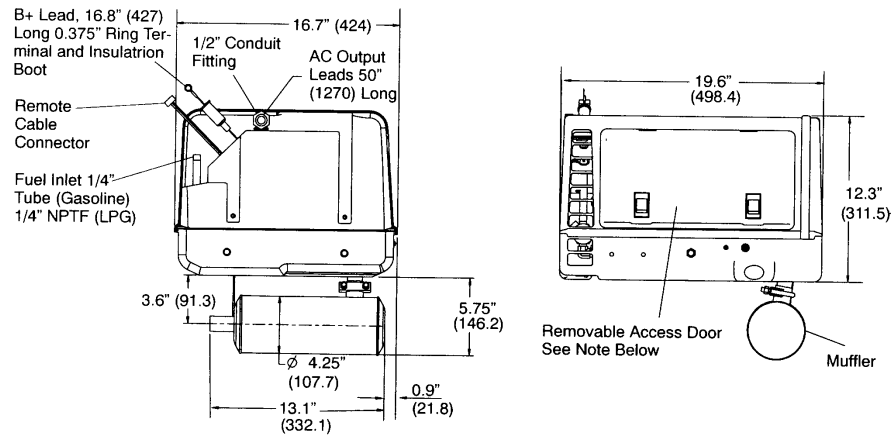

Note: Removable access cover for start/stop switch, fuse, oil check and fill, air cleaner service, governor adjustments, and carburetor adjustments.

## Muffler Kit 541-1050 - For use on 60 Hz and 50 Hz models

Muffler mounted in forward position

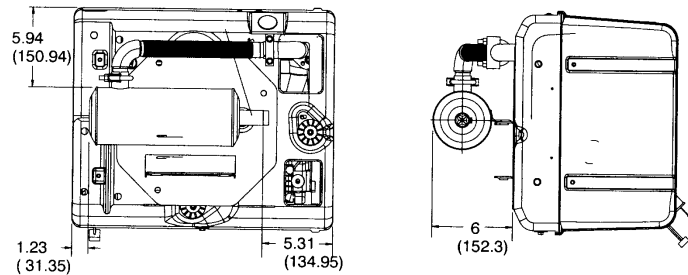

Muffler mounted in rear position

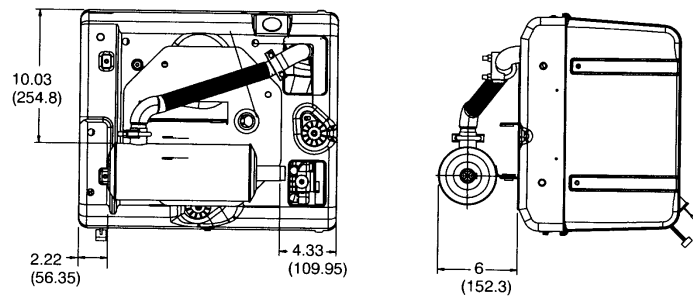

Dimensions in parentheses are millimeters. This outline drawing is provided for general reference only and is not intended for design or installation. For more information see installation manual or obtain outline drawing 500-3389 and wiring diagram from your Distributor/Dealer.

## Options and Accessories

- Remote start/stop rocker switch (P/N 300-4936)
- Remote Control with start/stop switch, and running time meter (P/N 300-4937)
- Remote control w/start/stop switch, and DC voltmeter (P/N 300-4938)
- Remote control plug and wire harness (10 ft - P/N 338-3489-01, 30 ft - P/N 338-3489-02)
- Remote Harness (P/N 300-4946)
- Battery, 12 V, 360 cold cranking amps at 0°F (-18°C) (P/N 416-0717)
- Under floor mounting kit (P/N 541-0661)
- USDA Forest Service approved spark arrester muffler kits available (P/N 541-0618 and 541-1050)
- Exhaust resonator (P/N 155-2449)
- Compartment mount installation template (P/N 539-2145)
- Under floor mount installation template (P/N 539-2146) (included in mounting kit P/N 541-0661)

## Onan Testing for RV Application

Tested at extremes of temperature -20° F (-29° C) to 120° F (49° C) for starting and operation.  
Tested with RV loads, air conditioners, microwaves, converter, TVs, VCRs.  
Tested installed. Onan owns RVs used for product development testing.  
Tested in high humidity conditions.  
Tested in salt spray conditions.  
Tested in heavy airborne dust conditions.  
Field Test program.  
60 Hz (120V only) models listed by SGS United States Testing Company, Inc. per ANSI/EGS-1 and CSA-certified per Electrical Bulletin 946.  
Ratings apply to altitudes up to 500 ft (150 m), 85° F (29° C) ambient with muffler, in RV enclosure.  
60 Hz models meet U.S. EPA and California emissions standards.



## Operating Temperature Range

Gasoline sets will operate from -20°F (-29°C) to 120°F (49°C). LPG sets will operate from 0°F (-18°C) to 120°F (49°C). LPG set starting and operation below 32°F (0°C) depends upon LP tank capacity, surface area and butane content of LPG.

## Warranty Policy

The Limited Warranty covers virtually everything except routine maintenance for the first two years you own your RV generator, and covers parts and labor on major power train and generator set parts during the third year. In addition, it also includes a free 90-day adjustment policy, which provides that Onan will make minor adjustments to your new genset during the first three months you own it - free of charge! Please note: The Onan 3-year Limited Warranty applies to RV generators used in RV applications only, and does not apply to RV generators used in commercial mobile applications.

For complete Onan Limited Warranty details see your Cummins Distributor or Onan Certified RV Service Dealer.

## After Sale Support

For your ongoing satisfaction and the dependability of your Onan RV generator, Onan offers a complete line of replacement and tune-up parts and oil and maintenance chemicals specifically designed for RV generators. Easy to find at certified Onan RV Service and Parts Dealers coast-to-coast, Onan Green Label Parts™ are packaged for correct selection and convenient on-board storage.

**EASY TO LOCATE ONAN CERTIFIED RV SERVICE AND PARTS DEALER** - Onan has trained, tested, and certified over 1000 dealers covering most major metropolitan areas in the U.S. and Canada. To easily locate a certified dealer, no matter where you travel, call 1-800-888-ONAN and ask us to send you an RV Service and Parts Dealer Directory (F-919) or visit [www.onan.com](http://www.onan.com).



## See Your Distributor for More Information:



Cummins Power Generation  
1400 73rd Avenue N.E.  
Minneapolis, MN 55432  
763.574.5000 ·  
1-800-888-ONAN ·  
Fax 763.574.8289 ·  
[www.onan.com](http://www.onan.com)

Cummins Power Generation is a subsidiary of Cummins Inc.  
Onan is a Registered Trademark of Cummins Inc.  
Cummins Power Generation is a subsidiary of Cummins Inc.  
Onan is a Registered Trademark of Cummins Inc.

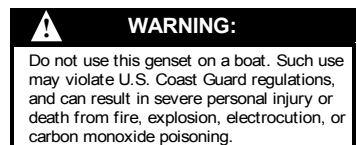

**WARNING:** Backfeed to a utility system can cause electrocution and/or property damage. Do not connect to any building electrical except through an approved device or after building main breaker is open.