

Diesel Generator Set

QSK60 Series Engine

EPA Emissions

1450kW - 2250kW 60Hz
1200kW - 2000kW 50Hz

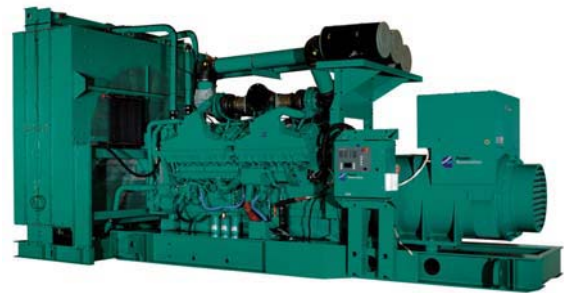

Optional Features Shown

Description

This Cummins Power Generation commercial generator set is a fully integrated power generation system, providing optimum performance, reliability and versatility for stationary standby, prime power and continuous duty applications.

This generator set is designed in facilities certified to ISO9001.



This generator set is manufactured in facilities certified to ISO9001 or ISO9002.

The Prototype Test Support (PTS) program verifies the performance integrity of the generator set design. Cummins Power Generation products bearing the PTS symbol meet the prototype test requirements of NFPA 110 for Level 1 systems.



All low voltage models are CSA certified to product class 4215-01.

The generator set is available Listed to UL2200, Stationary Engine Generator Assemblies. The PowerCommand control is Listed to UL508 - Category NITW7 for U.S. and Canadian usage. Circuit breaker assemblies are UL489 Listed for 100% continuous operation and also UL869A Listed Service Equipment.



Features

- **UL Listed Generator Set** - The complete generator set assembly is available Listed to UL2200.
- **Emissions Compliance** - All 60 Hz models comply with EPA emissions requirements for stationary applications. Some 60 Hz models comply with EPA TPEM requirements for mobile applications.
- **Cummins® Heavy-Duty Engine** - Rugged 4-cycle industrial diesel delivers reliable power, low emissions, and fast response to load changes.
- **Permanent Magnet Generator (PMG)** - Offers enhanced motor starting and fault clearing short circuit capability.
- **Alternator** - Several alternator sizes offer selectable motor starting capability with low reactance 2/3 pitch windings; low waveform distortion with non-linear loads, fault clearing short-circuit capability, and class F or H insulation.
- **Control System** - The PowerCommand® electronic control is standard equipment and provides total genset system integration, including automatic remote starting/stopping, precise frequency and voltage regulation, alarm and status message display, AmpSentry™ protection, output metering, auto-shutdown at fault detection, and NFPA 110 compliance.
- **Cooling System** - Standard integral set-mounted radiator system, designed and tested for rated ambient temperatures, simplifies facility design requirements for rejected heat.
- **Structural Steel Skid Base** - Robust skid base supports the engine, alternator, and radiator.
- **Warranty and Service** - Backed by a comprehensive warranty and worldwide distributor network.

Model	Standby Rating		Prime Power Ratings		Continuous Ratings		Data Sheets	
	60 Hz kW (kVA)	50 Hz kW (kVA)	60 Hz kW (kVA)	50 Hz kW (kVA)	60 Hz kW (kVA)	50 Hz kW (kVA)	60 Hz	50 Hz
DQKB	1750 (2188)	1500 (1875)	1600 (2000)	1350 (1688)	1450 (1813)	1200 (1500)	D-3220	D-3221
DQKC	2000 (2500)	1650 (2063)	1825 (2281)	1500 (1875)	1600 (2000)	1200 (1500)	D-3222	D-3223
DQKD	NA	1800 (2250)	NA	1600 (2000)	NA	1320 (1650)	NA	D-3250
DQKH	2250 (2813)	2000 (2500)	NA	NA	NA	NA	D-3235	D-3236

Control System



PowerCommand Digital Generator Set Control	
Operator Panel Features	
<ul style="list-style-type: none"> • Analog AC Metering Panel. Provides color-coded display of generator set output voltage, current, frequency, power factor, and kW. All phases of voltage and current are simultaneously displayed. Easy to see output status from a distance. • Graphical Data Display. Allows operator to view all engine and alternator data; perform operator adjustments for speed, voltage, and time delays; view fault history; and set-up and adjust the generator set. (Set up requires password access.) A portion of the display is allocated to display system status, including alarm and shutdown conditions. Display is controlled by sealed membrane switches. Up to 9 lines of data can be displayed, with approximately 26 characters per line. • LED Status Lamps. The status lamps indicate: Remote Start Command (green), Not in Auto (red-flashing), Warning (amber), and Shutdown (red). • Off/Manual/Auto Mode Select Switch and Run/Stop Switch. Mode selection switches allow remote automatic starting, or manual starting from the operator panel. Panel includes an LED lamp to indicate manual mode operation. • Exercise Switch. Automated exercise function in the control allows an operator to initiate an exercise period and have it automatically completed by the control. • Fault Reset Switch. Allows the operator to reset the control after a warning or shutdown condition. LED lamp with switch indicates that a fault is present on the system. • Panel Lamps and Switch. Operator panel can be illuminated by a series of high-intensity LED lamps, controlled by a membrane switch on the panel. Panel lamps include a time delay to automatically switch off after a preset time period. • Emergency Stop Switch. Provides positive and immediate shut down of the generator set on operation. • Construction. Operator panel is a sealed design with membrane switches for most functions. Mechanical switches are oil-tight design. Plug interfaces are provided to the generator set control system. Display panel labeling is configurable for language. 	
Standard Control Functions	Optional Features
<ul style="list-style-type: none"> • Integrated Isochronous governing and fuel control system. • Integrated 3-Phase sensing voltage regulation system, with automatic single and 3-phase fault regulation. • Integrated AC protective functions, include over/under voltage, short circuit, over current (warning and shutdown), and overload. • Integrated Engine management system, including configurable cycle-cranking functions and configurable start sequence. • Comprehensive warning and shutdown protection, including customer-configurable warning and shutdown conditions. • Comprehensive data displays, including 3-phase AC voltage, current, power factor, kW, and kVA; engine oil pressure, coolant temperature, DC volts, and other service functions; operating history (load and fault conditions); and system setup information. 	<ul style="list-style-type: none"> • Integrated Digital Paralleling Controls, including options for semi-automatic and automatic (isolated bus) applications. • LonMark Compliant network interface • Control Anti-condensation heater • Key-type mode select switch • Relay outputs for genset running, common warning, and common shutdown. • Exhaust Temperature Alarm • Alternator Temperature Alarm(s). • Centinel Lube Oil Burn System. • Power Transfer Control Function, to allow generator set to control remote power circuit breakers for open, fast closed, or soft (ramping) power transfer from a utility source to the genset (2 minute maximum fail-to-disconnect timer).

Ratings Definitions

Standby:	Prime (Unlimited Running Time):	Base Load (Continuous):
Applicable for supplying emergency power for the duration of normal power interruption. No sustained overload capability is available for this rating. This rating is applicable to installations served by a reliable normal utility source. This rating is only applicable to variable loads with an average load factor of 80 percent of the standby rating for a maximum of 200 hours of operation per year and a maximum of 25 hours per year at 100% of its standby rating. The standby rating is only applicable to emergency and standby applications where the generator set serves as the back up to the normal utility source. No sustained utility parallel operation is permitted with this rating. (Equivalent to Fuel Stop Power in accordance with ISO3046, AS2789, DIN6271 and BS5514). Nominally Rated.	Applicable for supplying power in lieu of commercially purchased power. Prime power is the maximum power available at a variable load for an unlimited number of hours. A 10% overload capability is available for limited time. (Equivalent to Prime Power in accordance with ISO8528 and Overload Power in accordance with ISO3046, AS2789, DIN6271, and BS5514). This rating is not applicable to all generator set models.	Applicable for supplying power continuously to a constant load up to the full output rating for unlimited hours. No sustained overload capability is available for this rating. Consult authorized distributor for rating. (Equivalent to Continuous Power in accordance with ISO8528, ISO3046, AS2789, DIN6271, and BS5514). This rating is not applicable to all generator set models.

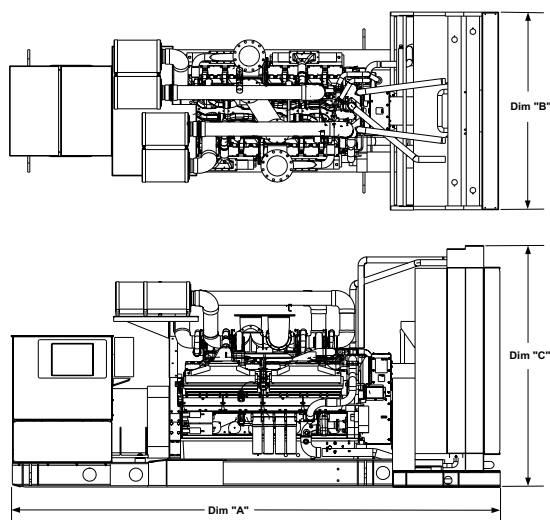

This outline drawing is to provide representative configuration details for Model series only.

See respective model data sheet for specific model outline drawing number.

Do not use for installation design

Model	Dim "A" mm (in.)	Dim "B" mm (in.)	Dim "C" mm (in.)	Dim "D" mm (in.)	Set Weight* dry kg (lbs)	Set Weight* wet kg (lbs)	w/Tank Dry weight kg (lbs)	w/Tank Wet weight kg (lbs)
DQKB	6175 (243)	2286 (90)	2537 (100)		14365 (31669)	14868 (32779)		
DQKC	6175 (243)	2286 (90)	2537 (100)		14649 (32296)	15152 (33405)		
DQKD	6175 (243)	2286 (90)	2537 (100)		14863 (32767)	15366 (33876)		
DQKH	6175 (243)	2494 (98)	3116 (123)		15254 (33629)	15781 (34790)		

*Note: Weights represent a set with standard features. See outline drawings for weights of other configurations. Dim "D" available only on models with sub-base fuel tank option.



See your distributor for more information.

Cummins Power Generation Americas
 1400 73rd Avenue N.E.
 Minneapolis, MN 55432 USA
 Telephone: +1 (763) 574-5000
 Fax: +1 (763) 574-5298
 Email: ask.powergen@cummins.com
 Web: www.cumminspower.com

Cummins and PowerCommand are registered trademarks of Cummins Inc. AmpSentry is a trademark of Cummins Inc.

Important: Back feed to a utility system can cause electrocution and/or property damage. Do not connect to any building's electrical system except through an approved device or after building main switch is open.